



# 产品规格书

## Sample Approval Sheet

敬 呈: To:

客 户 料 号: \_\_\_\_\_

Customer

P/N: \_\_\_\_\_

产 品 名 称:

Description:

卧式 FAKRA HORIZONTAL TYPE CONNECTOR

规 格 型 号:

Spec:

ANY TYPE

钿 威 料 号:

DIANWEI P/N

7.03A2.00082X

### 客 户 确 认 Customer Approve

承 办 Draft	审 核 Confirm	审 核 Approve

### 钿 威 科 技 DDIANWEI Technology

承 办 Draft	工 程 Engineer	审 核 Approve

## 东莞市钿威电子科技有限公司

DONGGUAN DIANWEI Electronic Technology CO.,LTD

厂址:东莞市塘厦镇沙湖社区大岭边路 22 号 邮编: 523725

Address:NO.22, DALINGBIAN ROAD, SHAHU COMMUNITY, TANGXIA TOWN, DONGGUAN CITY CHINA

Tel:+86-769-8788 8322

Fax:+86-769-8788 8321

E-Mail:dianwei@188.com

Http://www.dianwei.cn

1 2 3 4 5 6 7 8 9 10 11 12

图面类型

工程图纸

MARK	DATE	DESCRIPTION	DESIGN
A	2020.08.26	新发行	HJY

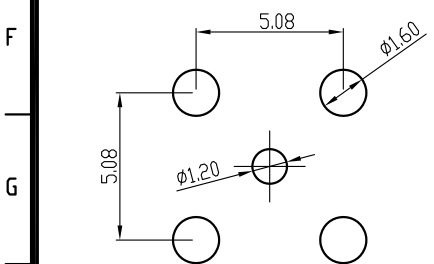
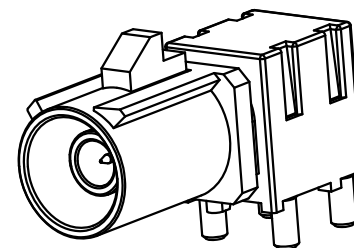
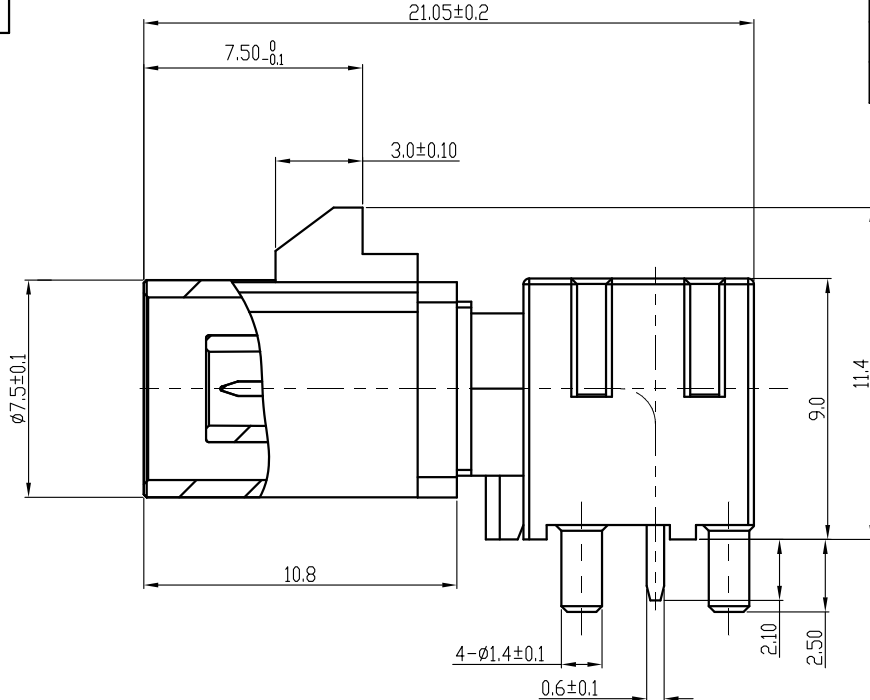
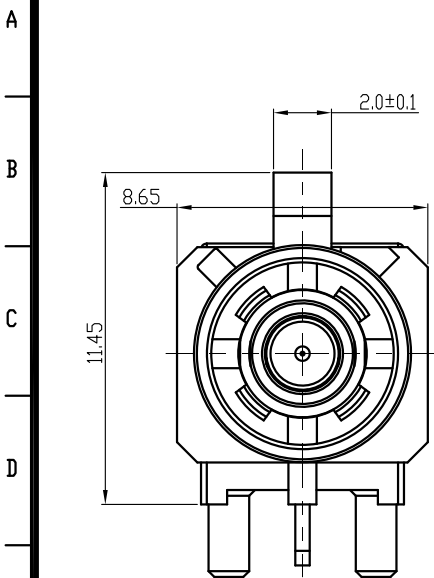

P.C.B LAYOUT

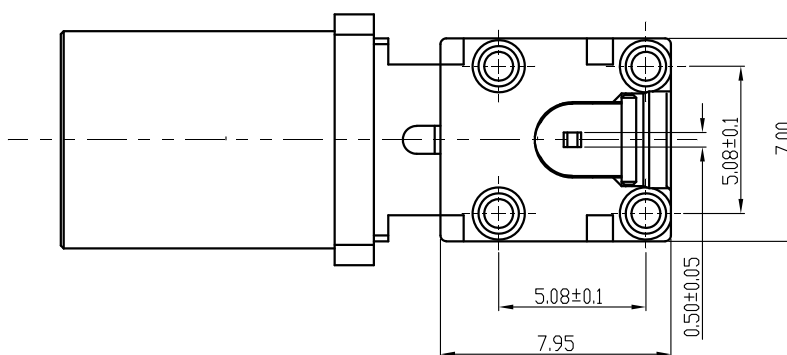

1. 料号: 7.03A1 .001 8 2 X  
L类型  
接触区: 镀金30u"  
焊接区: 镀锡80u"
2. 性能:
- 2.1: 接触阻抗: 50mOHM Max,
  - 2.2: 频率范围: DC to 6GHz
  - 2.3 驻波比: 0-6GHz 1.58Max
  - 2.4 额定电压: 50V (AC/DC).
  - 2.5: 额定电流: 1A/PIN.
  - 2.6: 绝缘电阻: 1000MOHM Min.
  - 2.7: 插拔次数: 25 TIMES Min.
  - 2.8: 工作温度: -40℃~+105℃

NOTE: ALL RIGHTS RESERVED,BANNED COPY!

UNLESS OTHERWISE SPECIFIED TOLERANCE			
ANG	TOL	DIM	TOL
.X	±3.0°	.X	±0.30
.XX	±2.0°	.XX	±0.20
.XXX	±1.0°	.XXX	±0.10

**DIANWEI**

东莞市钿威电子科技有限公司

DONGGUAN DIANWEI ELECTRONIC TECHNOLOGY CO., LTD

Tel: +86-769-8788 8322 Fax: +86-769-8788 8321 E-mail: dianwei@188.com Http://www.dianwei.cn

DRAWING NO		PART NAME:			
7.03A2		卧式连接器			
PART NO.		7.03A2.00182X			
DATE	UNITS	SCALE	PAGE	REV	
2020.08.26	mm	1:1	1/2	A	

DRAWING TYPE

CUSTOMER DRAWING

MARK	DATE	DESCRIPTION	DESIGN
A	2020.05.06	PROPOSAL	CHEN
B	2021.01.22	INCREASE SIZE	HJY

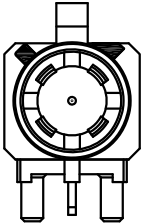
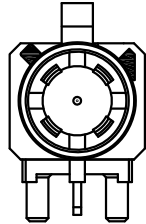
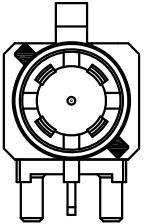
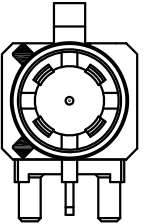
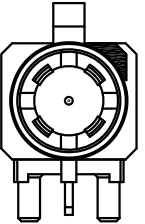
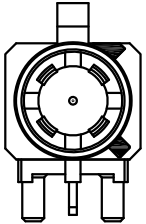
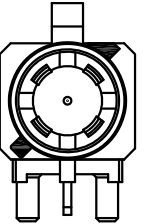
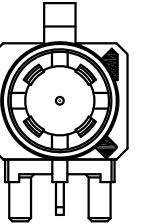
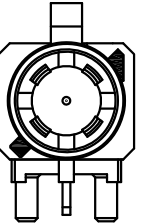
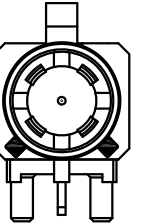
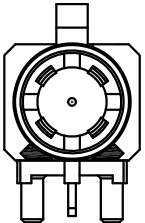
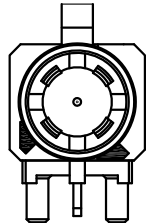
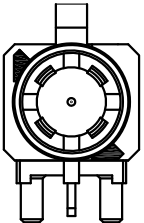
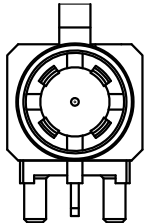
									
7.03A2.000820 A TYPE JET BLACK/9005	7.03A2.000821 B TYPE CREAM 9001	7.03A2.000822 C TYPE SIGNAL BLUE5005	7.03A2.000823 D TYPE CLARET VIOLET/4004	7.03A2.000824 E TYPE LEAF GREEN/6002	7.03A2.000825 F TYPE NUT BROWN/8011	7.03A2.000826 G TYPE BLUE GREY/7031	7.03A2.000827 H TYPE HEATHEA VIOLET/4003	7.03A2.000828 I TYPE BEIGE/1001	7.03A2.000829 K TYPE CURRY/1027
									
7.03A2.00082A L TYPE CARMINE RED/3002	7.03A2.00082B M TYPE PASTEL ORANGE/2003	7.03A2.00082C N TYPE PASTEL GREEN/6019	7.03A2.00082D Z TYPE AQUA BLUE/5021						

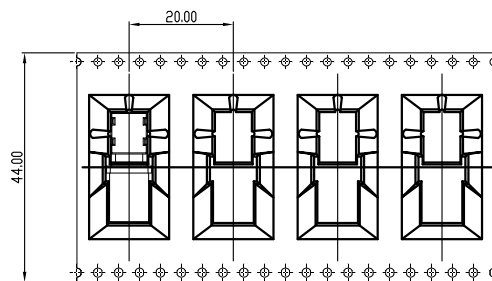

NOTE:  
1.PER REEL: 220PCS

NOTE: ALL RIGHTS RESERVED,BANNED COPY!

UNLESS OTHERWISE SPECIFIED TOLERANCE			
ANG	TOL	DIM	TOL
.X	±3.0°	.X	±0.30
.XX	±2.0°	.XX	±0.20
.XXX	±1.0°	.XXX	±0.10

# DIANWEI

东莞市钿威电子科技有限公司

DONGGUAN DIANWEI ELECTRONIC TECHNOLOGY CO., LTD

Tel: +86-769-8788 8322 Fax: +86-769-8788 8321 E-mail: dianwei@188.com Http://www.dianwei.cn

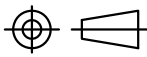
	DRAWING NO	PART NAME:	FAKRA VERTICAL TYPE CONNECTOR CUSTOMER DRAWING				
	7.03A2-C	PART NO.	7.03A2.00082X				
APPROVED	VERIFIED	DESIGN	DATE	UNITS	SCALE	PAGE	REV
		HJY	2021.01.22	mm	4:1	2/2	B

QP-04-33-B

Draft Dept. (制订部门): Engineering Dept.

Applicable Dept. (适用部门): QA Dept. (品保部) Eng. Dept. (工程部) MFG Dept. (制造部)

Rev. 版本	Issued Date 发行日期	Revised (制订、修订摘要)
A	2019.03.20	Released 新制定

Approve:

Check:

Draft: CHEN

This specification contains the design performance requirements that DIANWEI want to achieve, but the product described in this document has not been fully tested to ensure conformance to the requirements outlined below. Further, DIANWEI may change these requirements based on the results of additional testing and evaluation. Contact DIANWEI Engineering for further details.

本规范体现了钿威对所描述产品的设计意图，但具体的技术指标，请参考所描述产品相关的测试报告，钿威保留对此产品规范做更改的权利

未经本公司同意，不得拷贝本数据。

Without agreement in advance, it was forbidden to copy the data in this specification

## 1.Scope 文件范围

### 1.1 Content 内容

This specification covers performance, tests, quality & application requirements of DIANWEI FAKRA printed circuit board (PCB) connectors.

本规范涵盖钿威 FAKRA 印刷电路板(PCB)连接器的性能、测试、质量和应用要求

### 1.2Qualification 认证

When tests are performed on the subject product line, procedures specified in Figure 1 shall be used. All inspections shall be performed using the applicable inspection plan and product drawing.

当进行测试验证时，请按照图表 1 的内容进行测试验证

## 2.Applicable documents适用标准

Industry Documents 行业标准

2.1ISO20860-1-2008 Road vehicles — 50 ohms impedance radio frequency connection system interface

2.2SAE/USCAR-2 Rev 6 Automotive testing specification

2.3SAE/USCAR-17 Rev 4 FAKRA testing specification

2.4JSAE/USCAR-18 Rev 4 《FAKRA SMB Supplementary Specification for SMB RF connectors》

## 3. Requirements 具体要求

### 3.1 Design and construction 产品结构

Product shall be of the design, construction, materials and physical dimensions specified on the applicable product drawing. 在产品对应的图纸中定义产品的设计、结构、材料及物理尺寸等

### 3.2 Ratings 等级

## 4. Test Requirements and Procedures Summary 测试要求及规程:

一、 Visual Inspection 产品检查			
Item 项目	TEST DESCRIPTION 测试项目	REQUIREMENT 设计要求	PROCEDURE 参考规程
1	Visual Inspection 外观检查	Inspected using 10X scope and should be without crack,oxidation,pollution and burrs during previous processes 使用 10X 放大镜，检查产品在材料、加工、组装、后续存放等环节是否存在开裂、氧化、脏污、毛刺等不良	SAE/USCAR-2 Rev 6, 5.1.8.3
二.Electrical 电性能			
Item 项目	TEST DESCRIPTION 测试项目	REQUIREMENT 设计要求	PROCEDURE 参考规程
1	Contact Resistance 接触阻抗	$\leq 5 \text{ m}\Omega$ before, and $\leq 40 \text{ m}\Omega$ after 25 matings 信号及接地接触阻抗 $\leq 40 \text{ m}\Omega$ /25 次插拔后	ISO20860-1-2008
2	Dielectric Withstanding Voltage 耐压	$\geq 800 \text{ VAC}$	SAE/USCAR-17 Rev 4, 4.3.2.2
3	Working Voltage 额定电压	$\leq 60 \text{ V/DC}$	ISO20860-1-2008
4	Operating Current 额定电流	$\leq 1 \text{ A/DC}$	ISO20860-1-2008
5	Insulation Resistance 绝缘电阻	$\geq 1000 \text{ M}\Omega$ / (常态下) 环境试验后 $\geq 500 \text{ M}\Omega$	ISO20860-1-2008
6	VSWR 驻波比	SWR $\leq 1.5$ 0 to 3 GHz SWR $\leq 1.6$ 6 to 6 GHz	SAE/USCAR-17 Rev 4, 4.4.2.2
三. MECHANICAL 机械性能			

Item 项目	TEST DESCRIPTION 测试项目	REQUIREMENT 设计要求	PROCEDURE 参考规程
1	Solderability Dip Test 沾锡测试	Examined at 8X with 95% solder coverage 8X 放大镜下观察, 95%以上面积吃锡	JEDEC JESD22-B102E, Method 1
2	Mating cycles 插拔次数	25 cycles minimum 最少 25 次循环	ISO20860-1-2008
3	Connection insertion force 公母端插入力	≤ 25N	ISO20860-1-2008
4	Connection extraction force 公母端拔出力	≤ 25N	ISO20860-1-2008
5	Connector Disengage with Lock enabled 公母端分离力 (卡扣发挥作用)	Force to disengage ≥ 80N 分离力 ≥ 80N	ISO20860-1-2008
6	Gauge retention force centre contact 中心导体插入力	≥ 0.28N	ISO20860-1-2008
7	Gauge retention force outer contact 中心导体拔出力	≥ 2N	ISO20860-1-2008
8	Drop Test 跌落测试	Meets visual requirements 满足外观要求	SAE/USCAR-2 Rev 6, 5.4.8.3
9	Mechanical Pull and Sideload 外导体与壳体间的保持力	Force ≥ 110N Axial Force ≥ 75N Sideload	SAE/USCAR-17 Rev 4, 4.2.1.2

#### 四. ENVIRONMENTAL 环境性能

Item 项目	TEST DESCRIPTION 测试项目	REQUIREMENT 设计要求	PROCEDURE 参考规程
1	Vibration/Mechanical Shock 振动测试&机械冲击测试	No loss of electrical continuity VSWR check before and after 无大于 1 微秒的瞬断, 测试前后驻波比测试符合要求	SAE/USCAR-2 Rev 6, 5.4.6.3
2	Thermal Shock 冷热冲击	Group test compliance 符合群组测试要求	SAE/USCAR-17 Rev 4, 4.5.1.4 Cycle from -40 °C to +105 °C
3	Temperature/Humidity Cycling 温湿度循环	Group test compliance 符合群组测试要求	SAE/USCAR-2 Rev 6, 5.6.2.3 Cycle from -40 °C to +85 °C
4	High Temperature Exposure 高温寿命	Group test compliance 符合群组测试要求	SAE/USCAR-2 Rev 6, 5.6.3.3 Hold at +105 °C

#### 5.Group Test产品认证及再认证顺序:

##### A. Sampling 样品选择:

Sampling requested by below table shall be applicable to the principle of randomness  
样品选择应按照结构栏要求符合随意性原则

##### B. Sequence 测试顺序:

Below is test sequence

下列是群组检测顺序:

Test Content/sequence 测试认证顺序		Test Group 测试项目									
		B	F	G	H	K	N	O	Q	R	S
1	Visual Inspection 外观检查	Step1 Step4	Step1 Step3	Step1 Step4	Step1 Step3	Step1 Step3	Step1 Step5	Step1 Step7	Step1 Step7	Step1 Step7	Step1 Step7
2	Pin insert and withdraw force 端子与 Housing 的装入力及拔出保持力										
2.1	Inserting force $\cong 30N$ 端子装入 Housing, 插入力 $\cong 30N$	Step2									
2.2	Withdraw force $\cong 10N$ 端子拔出 Housing, 保持力 $\cong 10N$	Step3									
3	Withdraw force $\cong 10N$ Humidity conditioned 端子拔出 Housing, 保持力 $\cong 10N$ (温湿度预处理)		Step2								
4	Male and female engage and disengage force 连接器公母互配插入力&拔出力										
4.1	Male and female engage force $\cong 25N$ 公母互配插入力 $\cong 25N$			Step2							
4.2	Male and female engage and disengage force $\cong 110N$ (With lock enabled) 公母互配分离力 (卡扣发挥作用) $\cong 80N$			Step3							
5	Circuit Continuity Monitoring 电路导通监控				Step2		Step3	Step4	Step4		
6	Drop test 跌落测试					Step2					
7	VSWR&IR 驻波比及插损测试						Step2 Step4	Step2 Step5	Step2 Step5	Step2 Step5	Step2 Step5
8	Mechanical Pull 外导体与壳体间的保持力 $> \cong 110N$						Step3				
9	Durability 插拔寿命 $\cong 25$ 次							Step3	Step3	Step3	Step3
10	Contact resistance 接触阻抗 初始值: LLCR $\cong 5m\Omega$ 测试后: LLCR $\cong 40m\Omega$							Step2 Step5	Step2 Step5	Step2 Step5	
11	Isolation resistance $> 1000M\Omega$ 绝缘电阻 $> 1000M\Omega$									Step2 Step5	
12	Thermal shock 冷热冲击								Step4		
13	Temperature/Humidity Cycling 温湿度循环									Step4	
14	High Temperature Exposure 高温曝露										Step4
15	Dielectric Withstanding Voltage 耐压							Step6	Step6	Step6	Step6
16	Vibration/Mechanical Shock 振动/机械冲击							Step4			